



AquaRecessed

Barrier Free, Inverted, Fully Recessed,
Wall Mounted Water Cooler, 8 GPH

SUGGESTED SPECIFICATIONS

Model AI81408B is a self-contained, vandal resistant inverted and fully recessed pressure water cooler that shall deliver a minimum of 8.0 GPH (30.3 LPH) of water at 50°F (10°C) cooled from 80°F (26.7°C) inlet water and 90°F (32.2°C) ambient. Unit shall be activated by a brass, chrome plated front push button using less than 5 pounds of force. Bubbler shall be brass, chrome plated, with an integrally designed non-squirt feature and operate on a water pressure range of 20–105 psig. Cabinet panels shall be constructed from 304 stainless steel and the bowl shall have an integral drain. Evaporator shall be an insulated, tube on tank. Cooling system shall use R-134a refrigerant and be capillary tube controlled. An adjustable thermostat with an off position shall control the refrigeration system. Unit shall adhere to ANSI A117.1 and Americans with Disabilities Act of 1990 frontal approach and protruding objects requirements, **Child ADA** parallel and frontal approach and ANSI/NSF 61, Section 9. Unit shall be listed by Underwriters Laboratories for both the US and Canada, compliant to the Air Conditioning and Refrigeration Institute Standard 1010.

Stainless Steel Model:
AI81408B



STANDARD FEATURES

- Both Child and Adult ADA Compliant (when properly installed)
- 18 gage, 304 stainless steel cabinet
- 16 gage, galvanized mounting frame
- Polished chrome plated brass, anti-rotation non-squirt bubbler
- Copper tube on stainless steel tank evaporator
- 100 mesh inlet strainer
- Vandal resistant screws

Model Number	GPH*	Rated Watts	Full Load Amps	Approx. Shipping Weight
AI81408B	8.0	390	4.6	110 lbs.

* GPH of 50°F water at 90°F ambient room temperature and 80°F inlet water temperature
Compressor motor operates on 115 Volt / 60 Hz single phase.

OPTIONAL ACCESSORIES (additional costs)

- "F"** Flexible bubbler (Use model AI81408F)
 - GF2 Glass filler
 - SO Sensor operated
 - WF1 1500 gallon capacity, NSF 42+53, 1 micron lead reduction filter
 - 220V 220 volt/50Hz compressor (C€)
- Custom color finishes available upon request

Acorn Aqua™ assumes no responsibility for use of void or suspended data. © Copyright 2009 Acorn Aqua™, City of Industry, CA, A Division of Acorn Engineering Company. Please visit www.acornaqua.com for most current specifications.

Submittal # **AI81408B**
[Cat. 08/Sec. A] Rev A. 3/3/09

COMPLIES WITH STANDARDS



Test rating conditions are compliant with ARI 1010.



Member of Acorn Family of Companies

ACORN AQUA
15125 Proctor Avenue
City of Industry, CA
91746 U.S.A.
Phone 800-591-9360
626-336-4561
Fax 626-855-4894
www.acornaqua.com



TECHNICAL DIMENSIONS

All dimensions are nominal and subject to manufacturer's change without notice. Acorn Aqua™ assumes no responsibility for use of void or suspended data. © 2009 Acorn Aqua™, a Division of Acorn Engineering Company. Please visit www.acornaqua.com for most current specifications.

Stainless Steel Model:
AI81408B

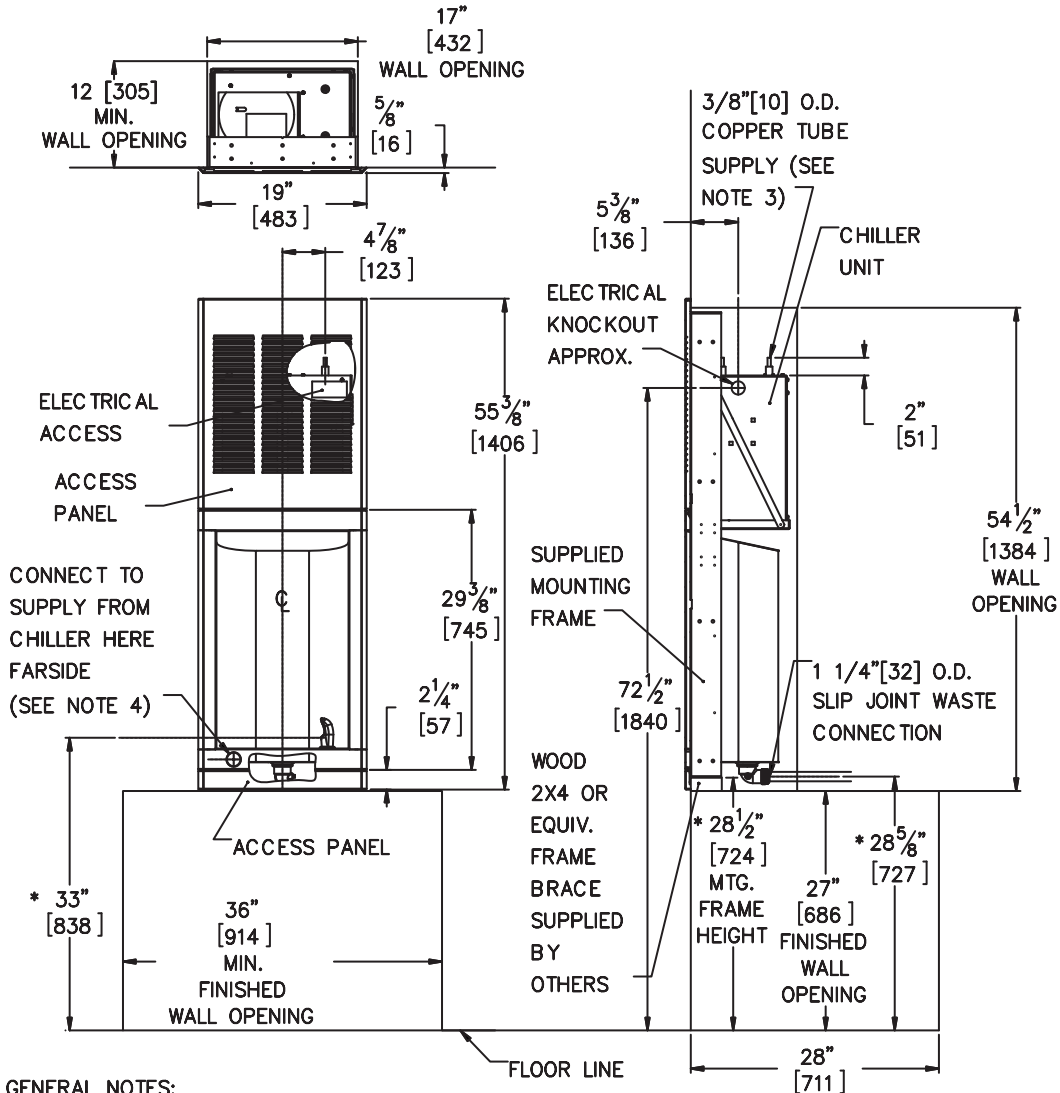

GENERAL NOTES:

1. ALL DIMENSIONS ARE IN INCHES [MM].
- *2. DIMENSIONS SHOWN ARE FOR RECOMMENDED ADULT HEIGHT. ADJUST VERTICAL DIMENSIONS
4. WATER LINE FROM CHILLER TO FOUNTAIN SHOULD BE COVERED WITH SPONGE RUBBER OR ICE WATER TYPE INSULATION OF ADEQUATE THICKNESS.

AquaRecessed Barrier Free, Inverted, Fully Recessed, Wall Mounted Water Cooler, 8 GPH

Rough-in # **AI81408B** 8/1/08

Five Year Limited Warranty- (Continental United States and Canada Only) The sealed refrigeration system and most major components are warranted for five (5) years. Other parts are warranted for one (1) year from date of installation.
Limited Export Warranty- One (1) year on parts only.

SELECTION SUMMARY & APPROVAL FOR MANUFACTURING	
Model Number & Options _____	Quantity _____
Company _____	Date _____
Contact _____	Title _____
Approval for Manufacturing/Signature _____	

Phone 800-591-9360
626-336-4561
www.acornaqua.com