

ELKAY[®]

SPECIFICATIONS

No Lead Space-ette[®] Floor-Mounted and Flush to Wall Water Cooler Models FD7003, FD7005 and FD70010

GENERAL

Self-contained, electric refrigerated floor model water cooler. Capacity of 50°F drinking water, based upon 80°F inlet water and 90°F ambient.

This model furnished with hermetically sealed combination tank-tube type cooling unit enclosed in cabinet. Cabinet design allows for flush to wall installation. Removable front panel and cabinet sides are Sandal-wood Vinyl.

Non-pressurized tank system is standard. Non-pressurized water tank is located after bubbler valve, so that tank is subject to line pressure only when valve button is pressed.

NO LEAD DESIGN

THIS WATER COOLER COMPLIES WITH THE LEAD-FREE DEFINITION IN THE SAFE DRINKING WATER ACT OF 1986 AND LEAD CONTAMINATION CONTROL ACT OF 1988.

Elkay Water Coolers are manufactured with a waterway system utilizing copper components and completely lead-free material. These waterways have no lead because all lead materials, such as leaded brass, have been removed. All joints are brazed using silver solder only. No lead solder is permitted. A strainer with an easily cleanable screen is provided to allow trapping and convenient removal of water born particulate of 140 microns and larger prior to their entry into the water cooler.

This water cooler is certified to NSF/ANSI 61.

CAPACITIES CHART

Model Number	Base Rate	**GPH of 50°F Drinking Water			Rated Watts	Full Load Amps	Glass Filler Option	Ship. Wt. Lbs.
		Room Temperature °F						
		70°F	80°F	90°F				
FD7003	3.0	3.6	3.3	3.0	230	2.5	Yes	54
FD7005	5.0	6.1	5.5	5.0	230	2.5	Yes	60
FD70010	9.8	11.9	10.8	9.8	535	5.8	Yes	69

**Based on 80°F inlet water temperature.

†Glass filler available at extra cost. Requires factory preparation to receive glass filler.

Rated watts shown are based on operational (run) time, in compliance with ARI Standard 1010 conditions. Specific applications will determine the actual watts consumed per hour. Watts consumed will be based on number of people served per hour (usage), ambient temperatures, and inlet water temperature.

COOLING SYSTEM

Motor Compressor: Hermetically sealed, reciprocating type, 115V, 60 Hertz single phase. Sealed-in lifetime oil supply. Equipped with electric cord and three prong molded rubber plug.

Condenser: Fan cooled, copper tube with aluminum fins. Fan motor is permanently lubricated.

Cooling Unit: Combination tube-tank type. Tube portion is continuous coil of copper tubing. Fully insulated with EPS foam which meets Underwriters Laboratories Inc. requirements for self extinguishing material.

Refrigerant Control: Refrigerant HFC-134a is controlled by accurately calibrated capillary tube for positively trouble free performance.

Temperature Control: Enclosed adjustable thermostat is factory pre-set. Requires no adjustment other than for altitude requirements.

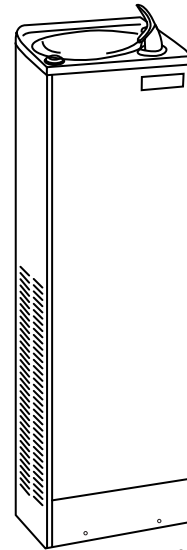

Model FD7005

CONSTRUCTION

Cabinet: Cabinet wrapper supports fountain top and all working mechanisms. Removable front panel and cabinet sides are Sandalwood vinyl. Stainless Steel cabinet available at extra cost.

Fountain Top: One piece stainless steel top, polished to a uniform Elkay bright luster finish. Unique Swirl-Flo basin has an integral vandal-resistant strainer, embossed bubbler pad.

Exclusive Flexi-Guard[®] Safety Bubbler*: Innovative design utilizes an infused anti-microbial pliable polyester elastomer to prevent accidental mouth injuries. Flexes on impact, then returns to original position. Strong. Abrasion-resistant. Anti-sweat. Keyed in location to prevent rotation.

STANDARDS



Elkay Electric Air Cooled Water Coolers meet the requirements of NSF/ANSI 61. Unit complies with A.R.I. Standard 1010.

* Patent #4,481,971

This specification describes an Elkay product with design, quality and functional benefits to the user. When making a comparison of other producers' offerings, be certain these features are not overlooked.

In keeping with our policy of continuing product improvement, Elkay reserves the right to change product specifications without notice.

Elkay

elkayusa.com

2222 Camden Court
Oak Brook, IL 60523

Printed in U.S.A.
©2006 Elkay

(Rev. 7/06)

9-5F

**No Lead Space-ette®
Floor-Mounted and Flush to Wall Water Cooler
Models FD7003, FD7005 and FD70010**

**ELKAY®
ROUGH-IN DIMENSIONS**

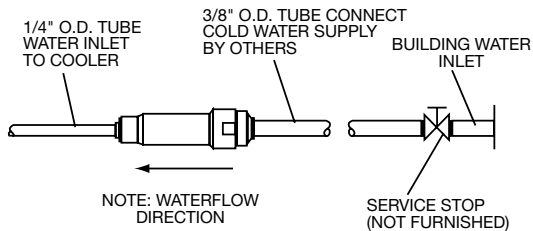

OPERATION OF QUICK CONNECT FITTINGS

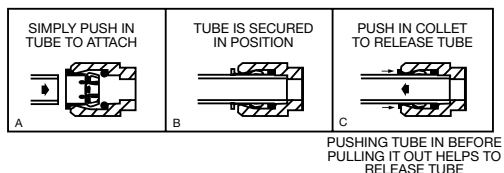

**IMPORTANT!
INSTALLER PLEASE NOTE:**

This water cooler has been designed and built to provide water to the user which has not been altered by materials in the cooler waterways. The grounding of electrical equipment such as telephone, computers, etc., to water lines is a common procedure. This grounding may be in the building but may also occur away from the building. This grounding can cause electrical feedback into a water cooler creating an electrolysis which creates a metallic taste or causes an increase in the metal content of the water. This condition is avoidable by installing the cooler using the proper materials as shown below.

NOTICE

This water cooler must be connected to the water supply using a di-electric coupling. The cooler is furnished with a non-metallic strainer which meets this requirement. The drain trap which is provided by the installer should also be plastic to completely isolate the cooler from the building plumbing system.

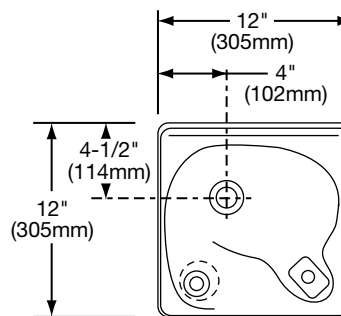

TOP VIEW

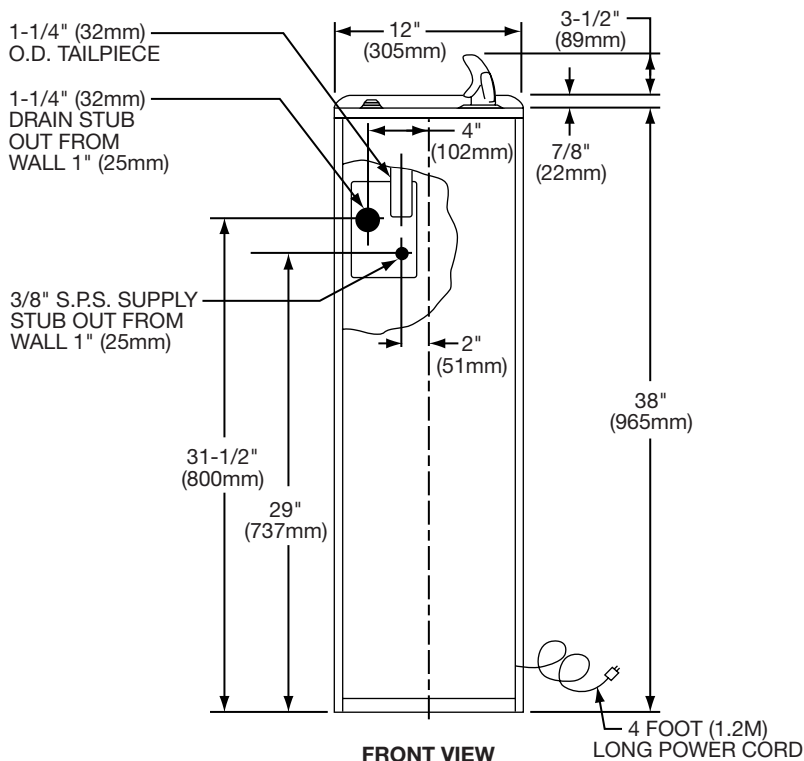

FRONT VIEW

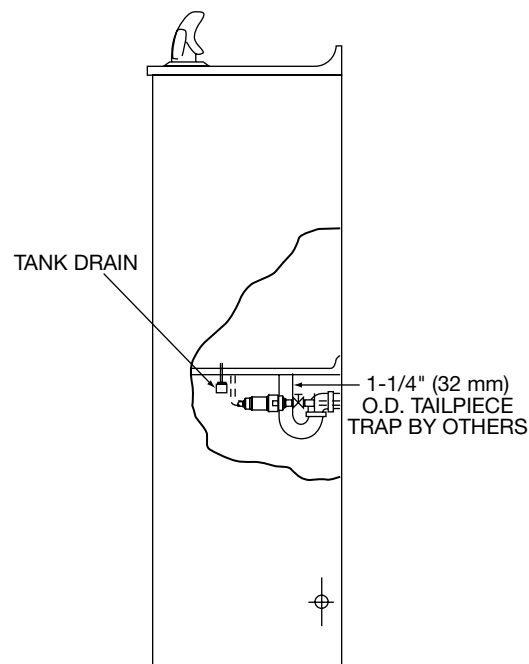

SIDE VIEW